

## Wireless Web Interface for Siemens S7 PLCs

### FEATURES

- Get PLC data table entries encoded in either JSON or XML
- Bidirectional data transfer supports both HTTP GET and POST
- Supports connections to five Siemens S7 PLCs
- Up to 150 read and 150 write requests per connection
- Effortless Browser Based Configuration, no programming software is required
- Simple data translation allows you to manipulate data as it passes between protocols
- 5-Year Hardware Warranty

### Access Your Siemens S7 PLC Data via a Web Interface over Wi-Fi

The 460WISC moves data between up to five Siemens S7 PLCs via Web Services. The gateway presents the S7 data as JSON or XML files transferred via HTTP commands over Wi-Fi using Wi-Fi IEEE 802.11 b/g/n at 2.4GHz with AES encryption 128-bit.

With the 460WISC, you are making a direct connection between XML/JSON data and the data table of your Siemens S7 PLC.

### How Do I Use the 460WISC-N2EW in My Application?

Incoming and outgoing ASCII data is mapped to and from memory table addresses in your Siemens S7 PLC. One area is output being mapped as XML or JSON to your applications. The other is input blocks receiving data from your application. It's really that simple.

### Why Use Real Time Automation as a Gateway Supplier?

While there are certainly other companies offering protocol gateways, there is no one who provides the level of support and service that you receive from RTA.

When you call, a live person answers the phone. When you talk with sales, you will get honest answers and recommendations. When you get support, it is from an engineer who had a hand in the product's development, and support doesn't require a ticket or 24-hour wait.

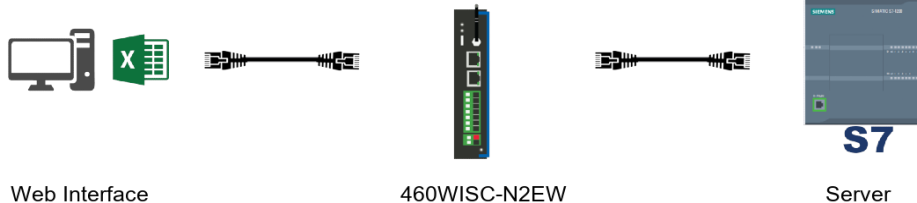

Web Interface

460WISC-N2EW

Server

**A Solution, A Philosophy, the RTA Way.** We understand the long hours spent on a factory floor and the pressure to keep a line running and product flowing. That's how Real Time Automation came to be. You want easy-to-use solutions where the hardest part is to open the box. You need customer support second to none. If you get all that and a fun customer experience all the better. Thirty years later, our mission remains the same: **To move your data where you need it, when you need it, and how you need it.**

WEB INTERFACE FEATURES	
Max Web Interface Connections	One (gateway acting as client) / Unlimited (gateway acting as server)
Encodings	JSON and XML
Proxy Support	HTTP, SOCKS5 for Client
Maximum Number of Input Data Points	1000 JSON Fields or 1000 XML Tags
Maximum Number of Output Data Points	1000 JSON Fields or 1000 XML Tags
HTTP Services	Client: POST only; Server: GET and POST
Siemens S7 CLIENT FEATURES	
PLC Support	S7 300/400/1200/1500
Maximum Number of PLCs Supported	5
Maximum Number of Inputs/Outputs per PLC	150
Maximum Number of Bytes per Scan Line	400
Memory Area Access	Input (I), Output (Q), and Data Block( DB)
Supported Data Types	8 Bit Int, 16 Bit Int, 32 Bit Int, 32 Bit Float, Bool and Char Array
INCLUDED WITH GATEWAY	
3' power cable with flying leads	5-year hardware warranty
IPSetup software – automatically locates RTA gateway on the network	Unlimited firmware feature upgrades for life
CAT5 crossover cable for direct connection to PC during programming	Complete, unlimited access to our industry leading support staff
Manual	

ELECTRICAL / ENVIRONMENTAL	
DC Input Voltage	12-24 VDC
Maximum Baud Rate	115K baud
Operating Temperature	-40 C to 85 C
Certification	RoHS-Compliant, UL, CUL, CE Approvals, Class I Div 2
ENCLOSURE / HARDWARE	
Size	5.40" x 3.83" x 1.19"
Weight	7.6 oz
Enclosure Type	Anodized Aluminum
Mounting	Din rail or panel mount
LEDs	Power LED & 2 general purpose LEDs on side
GATEWAY FEATURES & FUNCTIONS	
Alarming	Set <, <=, >, >=, ==, !=, and change-of-state rules on any data moving through the gateway. If alarm rule is triggered an email notification can be sent.
Gateway Security	You can configure up to 9 different users access to diagnostic and configuration screens.
Translation Table	Allows for data manipulation during protocol translation. Scaling and other data format changes can occur in the gateway.
Status and Counters	Protocol specific status, counters, and error messages are accessible within the gateway's diagnostics page. They can also be delivered to a connected device.
Diagnostic Logging Page	Allows users to see and log start up sequences, protocol specific messages & error messages.

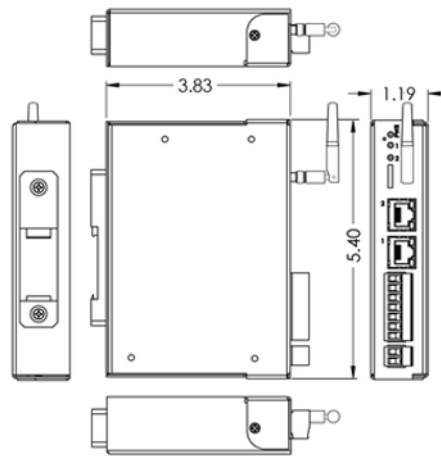

**NOT EXACTLY WHAT YOU WERE LOOKING FOR?**  
 Real Time Automation offers a full line of gateway products. Give us a call at 1-800-249-1612. Or, check out a listing at [www.rtautomation.com/products](http://www.rtautomation.com/products). We also offer customizations for unique applications.

CATALOG #	DESCRIPTION
460WISC-N2EW	Connect up to five Siemens S7 PLCs via a web interface over Wi-Fi



ALWAYS IN STOCK



READY TO SHIP

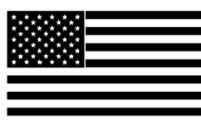

MADE IN THE USA



EXPERT SUPPORT



5-YEAR WARRANTY



EMPLOYEE OWNED